

Cod: 87185090

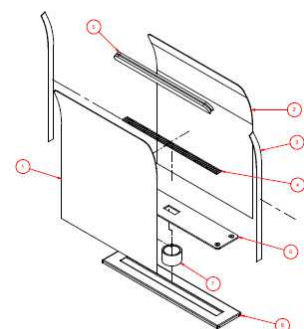
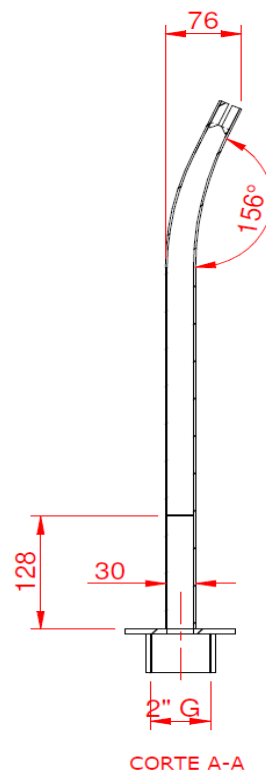
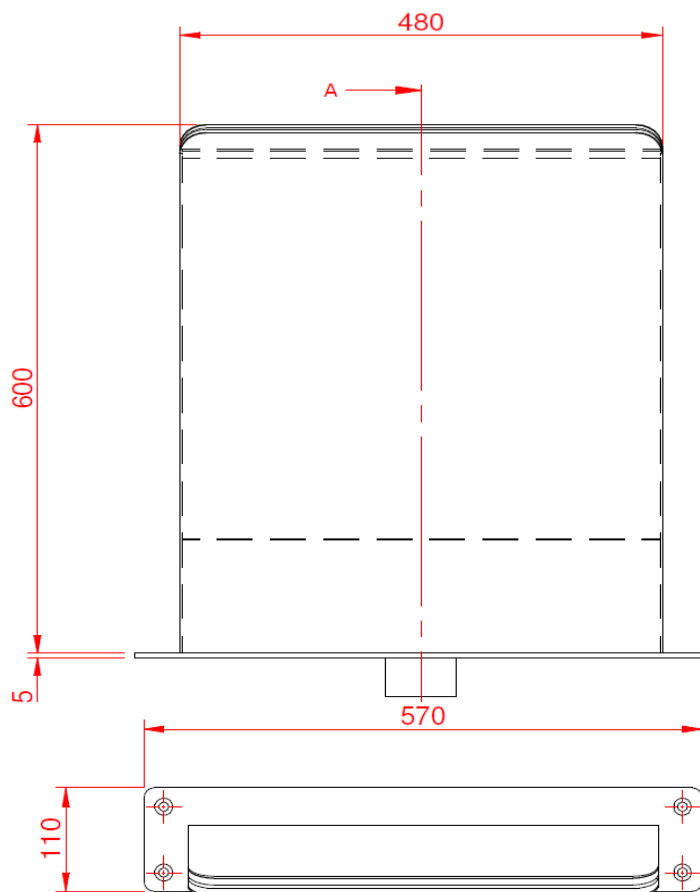

Características:

- Fabricadas con chapa de acero inoxidable A-316L 2 mm de grosor.
- Acabado Decapado, Pasivado y Pulido Brillante, con embellecedor incluido.
- No requiere Anclaje. Conexión Hembra 2" y Tornillos incluidos.
- Caudal: 10 m³/h. Bomba recomendada 0,33 kW.