

# CF-2

**Bomba centrífuga para piscina**  
*Centrifugal pump for swimming pool*  
Pompe de piscine centrifuge

efficiency class

**IE3**



- ✓ **Fabricada íntegramente en fundición de hierro**  
*Made entirely in full cast iron*  
Entièrement en fonte
- ✓ **Eje en acero inoxidable AISI-316**  
*AISI-316 stainless steel shaft*  
Manche en acier inoxydable AISI-316
- ✓ **Sello mecánico en carbón-cerámica**  
*Mechanical seal in carbon-ceramic*  
Garniture mécanique en carbone-céramique
- ✓ **Prefiltro de grandes dimensiones**  
*Large Prefilter*  
Grand préfiltre
- ✓ **Turbina en bronce bajo demanda**  
*Bronze impeller on demand*  
Turbine en bronze sur demande



Compatible con variador [e]POOL + soporte pared  
*Compatible with [e]POOL inverter + wall support*



BR-2



- |   |   |  |
|---|---|--|
| ➤ Conexión brida desde DN-80 a DN-125                 | Flange connection from DN-80 to DN-125                | Raccordement à bride de DN-80 à DN-125                   |
| ➤ Cesto prefiltro fabricado en AISI-316               | Prefilter basket made of AISI-316                     | Panier de préfiltre en AISI-316                          |
| ➤ Bajo demanda sello mecánico en carburo de silicio   | On demand mechanical seal in silicon carbide          | Joint mécanique à la demande en carbure de silicium      |
| ➤ Se puede suministrar completamente en bronce (BR-2) | It can be supplied completely in bronze (BR-2)        | Il peut être fourni complètement en bronze (BR-2)        |
| ➤ Tornillería en acero inoxidable AISI-316            | Stainless steel screws AISI-316                       | Vis en acier inoxydable AISI-316                         |
| ➤ Motor normalizado IE3 a 2900 rpm (3450 rpm @ 60 Hz) | IE3 standardized motor at 2900 rpm (3450 rpm @ 60 Hz) | Moteur normalisé IE3 à 2900 tr/min (3450 tr/min @ 60 Hz) |
| ➤ Rodamientos lubricados de por vida                  | Lubricated bearings for life                          | Roulements lubrifiés à vie                               |
| ➤ Grado IP-55, Aislamiento clase F                    | IP-55 Grade, Class F Insulation                       | Isolation IP-55, classe F                                |

Datos Técnicos / Technical data / Données techniques

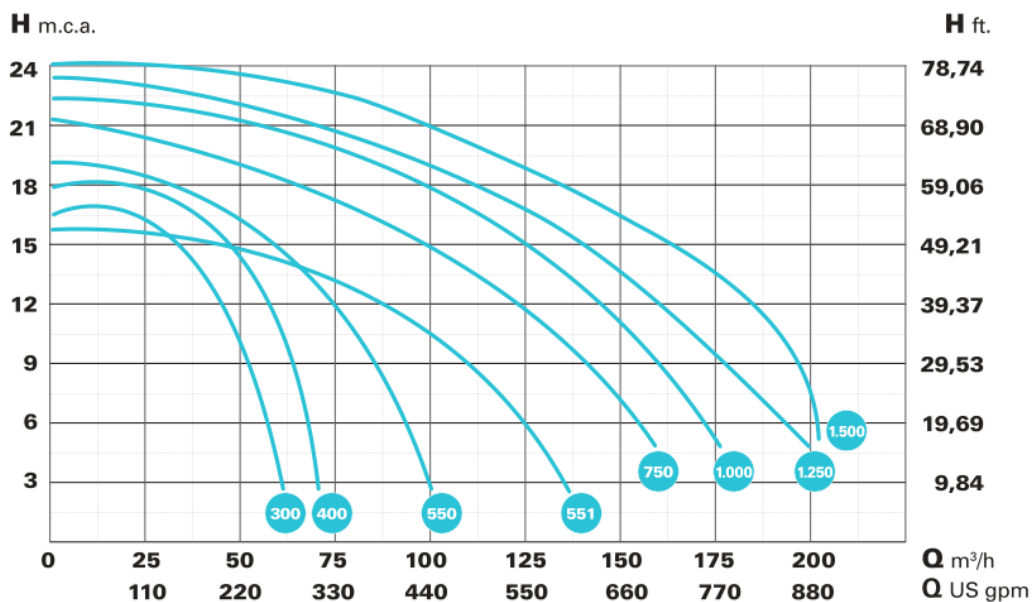

Tipo / Type		HP	KW	A		Altura manométrica m.c.a. / Manometric height w.c.m.										DNA	DNI
Hierro Cast Iron	Bronce Bronze			230V	400V	6	8	10	12	14	16	18	20	22			
Caudal m³/h / Flow m³/h																	
CF-2 300	BR-2 300	3	2,2	7,6	4,4	61	54	51	46	35	29	-	-	-	DN80	DN80	
CF-2 400	BR-2 400	4	3	10	5,8	70	64	59	55	49	42	30	-	-	DN80	DN80	
CF-2 550	BR-2 550	5,5	4	13,3	7,7	95	90	84	77	65	54	32	-	-	DN125	DN100	
CF-2 551	BR-2 551	5,5	4	13,3	7,7	128	121	107	90	69	30	-	-	-	DN125	DN100	
CF-2 750	BR-2 750	7,5	5,5	17,5	10,1	159	152	135	125	109	88	60	-	-	DN125	DN100	
CF-2 1000	BR-2 1000	10	7,5	-	13,7	175	166	158	147	135	119	98	68	-	DN125	DN100	
CF-2 1250	BR-2 1250	12,5	9,2	-	19,4	195	188	175	163	150	136	105	86	-	DN125	DN100	
CF-2 1500	BR-2 1500	15	11	-	19,4	200	197	193	183	170	155	132	110	87	DN125	DN100	

# HF-2

**Bomba de alta presión para piscina**  
*High pressure swimming pool pump*  
Pompe piscine haute pression

efficiency class

**IE3**



- ✓ **Fabricada íntegramente en fundición de hierro**  
*Made entirely in full cast iron*  
Entièrement en fonte
- ✓ **Eje en acero inoxidable AISI-316**  
*AISI-316 stainless steel shaft*  
Manche en acier inoxydable AISI-316
- ✓ **Prefiltro de grandes dimensiones**  
*Large Prefilter*  
Grand préfiltre
- ✓ **Turbina en bronce bajo demanda**  
*Bronze impeller on demand*  
Turbine en bronze sur demande
- ✓ **Ideal para filtración a grandes alturas**  
*Ideal for high heights filtrations*  
Idéal pour la filtration en hauteur



Compatible con variador [e]POOL + soporte pared  
*Compatible with [e]POOL inverter + wall support*



- Conexión brida desde DN-80 a DN-125      *Flange connection from DN-80 to DN-125*      *Raccordement à bride de DN-80 à DN-125*
- Cesto prefiltro fabricado en AISI-316      *Prefilter basket made of AISI-316*      *Panier de préfiltre en AISI-316*
- Bajo demanda sello mecánico en carburo de silicio      *On demand mechanical seal in silicon carbide*      *Joint mécanique à la demande en carbure de silicium*
- Tornillería en acero inoxidable AISI-316      *Stainless steel screws AISI-316*      *Vis en acier inoxydable AISI-316*
- Motor normalizado IE3 a 2900 rpm (3450 rpm @ 60 Hz)      *IE3 standardized motor at 2900 rpm (3450 rpm @ 60 Hz)*      *Moteur normalisé IE3 à 2900 tr/min (3450 tr/min @ 60 Hz)*
- Rodamientos lubricados de por vida      *Lubricated bearings for life*      *Roulements lubrifiés à vie*
- Grado IP-55, Aislamiento clase F      *IP-55 Grade, Class F Insulation*      *Isolation IP-55, classe F*

Datos Técnicos / Technical data / Données techniques

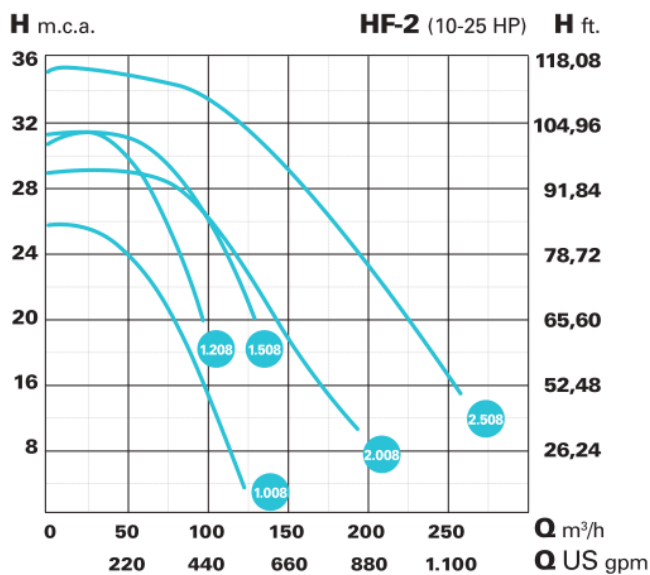
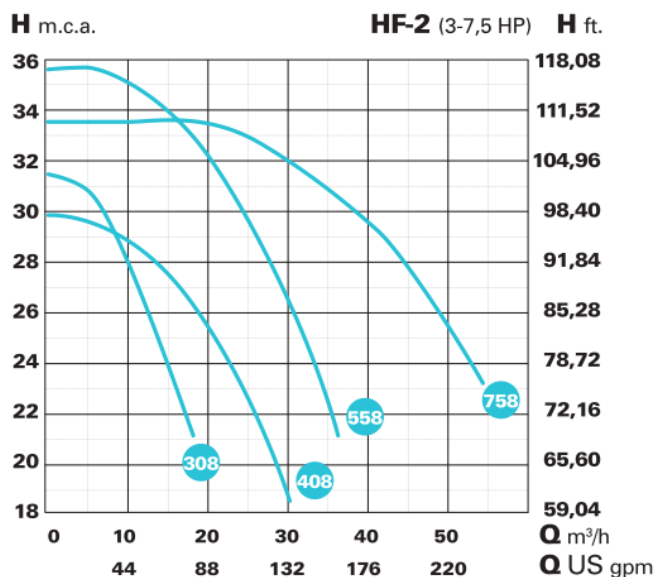

Tipo / Type	HP	KW	A		Altura manométrica m.c.a. / Manometric height w.c.m.								
			230V	400V	18	20	22	24	25	27	30	32	35
Caudal m³/h / Flow m³/h													
HF-2 308	3	2,2	7,6	4,4	-	-	18	16	14	12	-	-	-
HF-2 408	4	3	10	5,8	-	29	26	24	22	18	6	-	-
HF-2 558	5,5	4	13,3	7,7	-	-	36	34	33	30	25	21	12
HF-2 758	7,5	5,5	-	10,1	-	-	-	54	52	48	41	32	-
HF-2 1008	10	7,5	-	13,7	102	92	83	64	62	42	-	-	-
HF-2 1208	10	7,5	-	13,7	-	-	-	88	84	74	56	36	-
HF-2 1508	15	11	-	19,4	-	-	-	117	113	102	78	54	-
HF-2 2008	20	15	-	26,5	-	165	140	125	118	114	85	-	-
HF-2 2508	25	18,5	-	32,5	-	240	225	200	190	175	145	125	72



# CF-2

Datos embalage  
Packaging data  
Données d'emballage

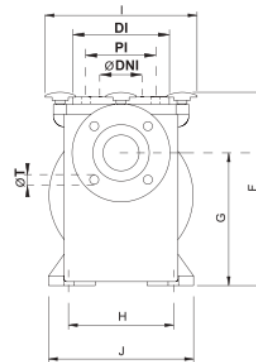
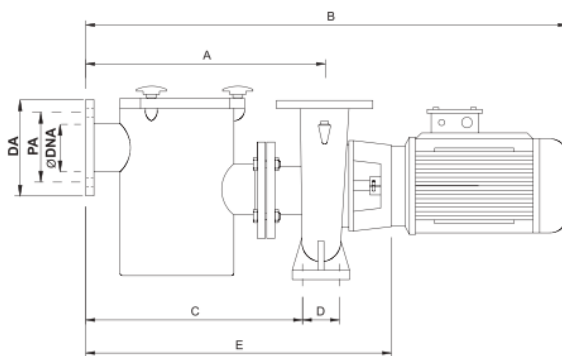
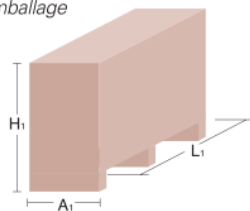

Tipo / Type Hierro Cast Iron	Modelos / Types a 2.900 r.p.m.										Aspiración / Inlet				Impulsión / Output				Embalaje / Package		Peso kg.				
	A	B	C	D	E	F	G	H	I	J	Ø DNA	DA	PA	Nº T	Ø T	Ø DNA	DI	PI	Nº T	Ø T	L1	A1	H1	Hi	Br
<b>CF-2 300</b>	492	950	458	68	632	425	262	190	300	240	80	200	160	4	18	80	200	160	4	18	1,170	400	660	75	90
<b>CF-2 400</b>	492	950	458	68	632	425	262	190	300	240	80	200	160	4	18	80	200	160	4	18	1,170	400	660	79	96
<b>CF-2 550</b>	504	1029	455	100	676	425	275	215	300	285	125	250	210	8	18	100	220	180	8	18	1,170	400	660	104	124
<b>CF-2 551</b>	504	1029	455	100	676	425	275	215	300	285	125	250	210	8	18	100	220	180	8	18	1,170	400	660	104	124
<b>CF-2 750</b>	504	1111	455	100	676	425	275	215	300	285	125	250	210	8	18	100	220	180	8	18	1,170	400	660	121	140
<b>CF-2 1000</b>	528	1156	470	110	722	458	315	258	300	330	125	250	210	8	18	100	220	180	8	18	1,170	400	660	140	163
<b>CF-2 1250</b>	528	1156	470	110	722	458	315	258	300	330	125	250	210	8	18	100	220	180	8	18	1,170	400	660	148	163
<b>CF-2 1500</b>	528	1156	470	110	722	458	315	258	300	330	125	250	210	8	18	100	220	180	8	18	1,170	400	660	148	168

Denominación recambios  
Spare-part description  
Dénomination des pièces

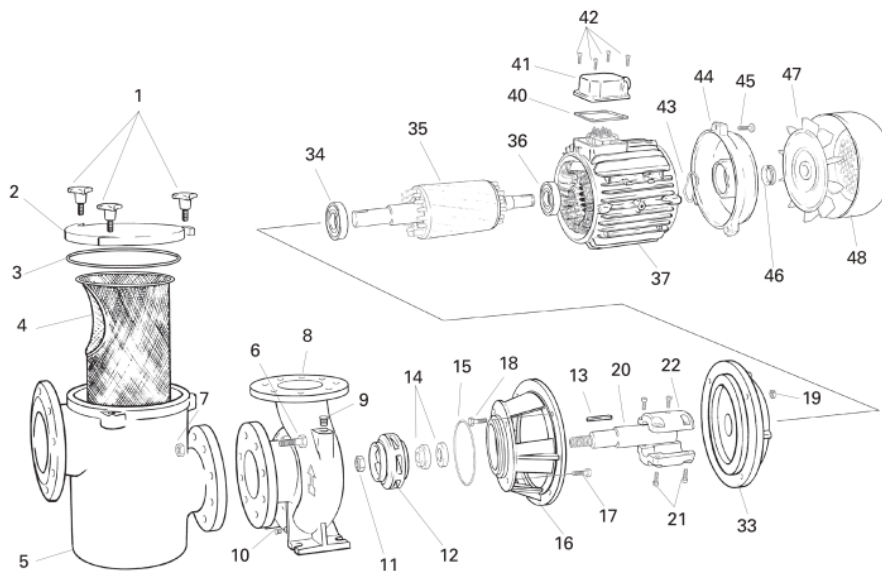

- 1 - POMO PREFILTRO
- 2 - TAPA REGISTRO PREFILTRO
- 3 - JUNTA TAPA REGISTRO
- 4 - CESTA PREFILTRO
- 5 - PREFILTRO
- 6 - TORNILLO PREFILTRO-CUERPO
- 7 - TUERCA PREFILTRO-CUERPO
- 8 - CUERPO BOMBA
- 9 - TORNILLO CEBADO
- 10 - TORNILLO VACIADO
- 11 - TUERCA TURBINA
- 12 - TURBINA
- 13 - CHAVETA
- 14 - CIERRE MECÁNICO
- 15 - JUNTA TORICA CUERPO BOMBA
- 16 - SOPORTE BOMBA MOTOR
- 17 - TORNILLO SOPORTE-CUERPO
- 18 - TORNILLO SOPORTE-MOTOR

- 19 - TUERCA TORNILLO SOPORTE-MOTOR
- 20 - EJE BOMBA
- 21 - TORNILLO ALLEN ACOPLAMIENTO
- 22 - ACOPLAMIENTO
- 33 - TAPA DELANTERA MOTOR
- 34 - RODAMIENTO DELANTERO
- 35 - EJE ROTOR
- 36 - RODAMIENTO TRASERO
- 37 - ESTATOR CON CARCASA
- 40 - JUNTA TAPA CONEXIONES
- 41 - TAPA BORNES
- 42 - TORNILLO TAPA BORNES
- 43 - ARANDELA LASAJE
- 44 - TAPA TRASERA MOTOR
- 45 - TORNILLO TAPA TRASERA
- 46 - RETÉN TAPA TRASERA MOTOR
- 47 - VENTILADOR
- 48 - TAPA VENTILADOR

- 1 - PRE-FILTER HANDLE
- 2 - PRE-FILTER INSPECTION COVER
- 3 - INSPECTION COVER SEAL
- 4 - PRE-FILTER BASKET
- 5 - PRE-FILTER
- 6 - PRE-FILTER-BODY BOLT
- 7 - PRE-FILTER-BODY NUT
- 8 - PUMP BODY
- 9 - FILLING BOLT
- 10 - EMPTYING BOLT
- 11 - IMPELLER NUT
- 12 - IMPELLER
- 13 - PIN
- 14 - MECHANICAL SEAL
- 15 - PUMP BODY O-RING
- 16 - MOTOR PUMP SUPPORT
- 17 - BODY SUPPORT BOLT
- 18 - MOTOR SUPPORT BOLT

- 19 - MOTOR SUPPORT NUT FOR BOLT
- 20 - PUMP SHAFT
- 21 - COUPLING ALLEN BOLT
- 22 - COUPLING
- 33 - FRONT MOTOR COVER
- 34 - FRONT BEARING
- 35 - ROTOR SHAFT
- 36 - REAR BEARING
- 37 - STATOR WITH HOUSING
- 40 - JUNCTION COVER SEAL
- 41 - JUNCTION COVER
- 42 - JUNCTION COVER BOLT
- 43 - LASAJE WASHER
- 44 - MOTOR REAR COVER
- 45 - REAR COVER BOLT
- 46 - MOTOR REAR COVER RETAINER
- 47 - VENTILATOR
- 48 - VENTILATOR COVER

- 1 - POIGNÉE PRÉFILTRE
- 2 - CAPOT CONTRÔLE PRÉFILTRE
- 3 - JOINT CAPOT CONTRÔLE
- 4 - BAC PRÉFILTRE
- 5 - PRÉFILTRE
- 6 - VIS PRÉFILTRE-CORPS
- 7 - ÉCROU PRÉFILTRE-CORPS
- 8 - CORPS POMPE
- 9 - VIS GRAISSÉE
- 10 - VIS À VIDE
- 11 - ÉCROU TURBINE
- 12 - TURBINE
- 13 - GOUPILLE
- 14 - FERMETURE MÉCANIQUE
- 15 - JOINT TORIQUE CORPS POMPE
- 16 - SUPPORT POMPE MOTEUR
- 17 - VIS CORPS-SUPPORT
- 18 - VIS SUPPORT-MOTEUR

- 19 - ÉCROU VIS SUPPORT-MOTEUR
- 20 - AXE POMPE
- 21 - VIS ALLEN COUPLE
- 22 - COUPLE
- 33 - CAPOT AVANT MOTEUR
- 34 - ROULEMENT AVANT
- 35 - AXE ROTOR
- 36 - ROULEMENT ARRIÈRE
- 37 - STATOR AVEC CARCASSE
- 40 - VIS À VIDE
- 41 - CAPOT CONNEXIONS
- 42 - VIS CAPOT CONNEXIONS
- 43 - RONDELLE DE BUTÉE
- 44 - CAPOT ARRIÈRE MOTEUR
- 45 - VIS CAPOT ARRIÈRE
- 46 - BUTÉE CAPOT ARRIÈRE MOTEUR
- 47 - VENTILATEUR
- 48 - CAPOT VENTILATEUR

# HF-2

Datos embalage  
Packaging data  
Données d'emballage

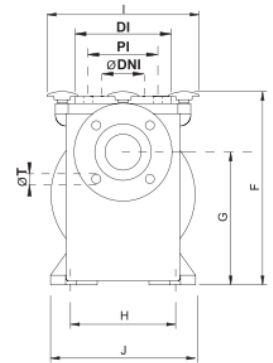
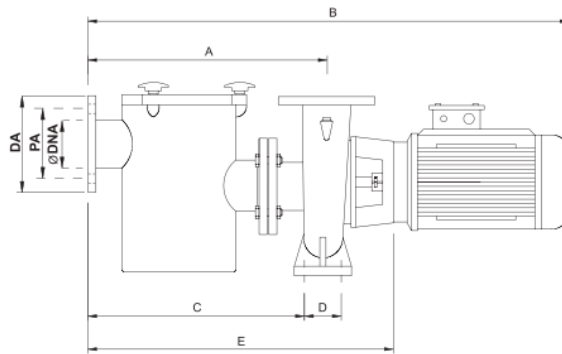
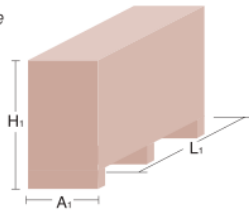

Tipo / Type	Modelos / Types a 2.900 r.p.m.										Aspiración / Inlet				Impulsión / Output				Embalaje / Package			Peso kg.		
	A	B	C	D	E	F	G	H	I	J	ØDNA	DA	PA	N° T	Ø T	Ø DNI	DI	PI	N° T	Ø T	H1		A1	L1
<b>HF-2 308</b>	460	878	425	70	606	415	262	190	265	245	65	185	145	4	18	32	140	100	4	16	660	400	1,170	94
<b>HF-2 408</b>	460	890	425	70	634	415	262	190	265	245	65	185	145	4	18	32	140	100	4	16	660	400	1,170	105
<b>HF-2 558</b>	460	890	425	70	634	415	262	190	265	245	65	185	145	4	18	32	140	100	4	16	660	400	1,170	115
<b>HF-2 758</b>	460	1075	425	70	673	415	262	190	305	300	65	185	145	4	18	40	150	110	4	18	660	400	1,170	140
<b>HF-2 1008</b>	480	1095	445	70	693	415	262	190	305	300	65	185	145	4	18	40	150	110	4	18	660	400	1,170	155
<b>HF-2 1208</b>	480	1095	445	70	693	415	290	212	306	301	65	185	145	4	18	50	165	125	4	18	660	400	1,170	176
<b>HF-2 1508</b>	480	1261	-	-	723	415	290	254	355	350	80	200	160	8	18	65	185	145	8	18	430	355	1,261	272
<b>HF-2 2008</b>	505	1286	-	-	748	415	295	254	355	350	100	220	180	8	18	80	200	160	4	18	430	355	1,286	355
<b>HF-2 2508</b>	505	1286	-	-	748	415	295	279	355	350	100	220	180	8	18	80	200	160	4	18	430	355	1,286	385

Denominación recambios  
Spare-part description  
Dénomination des pièces

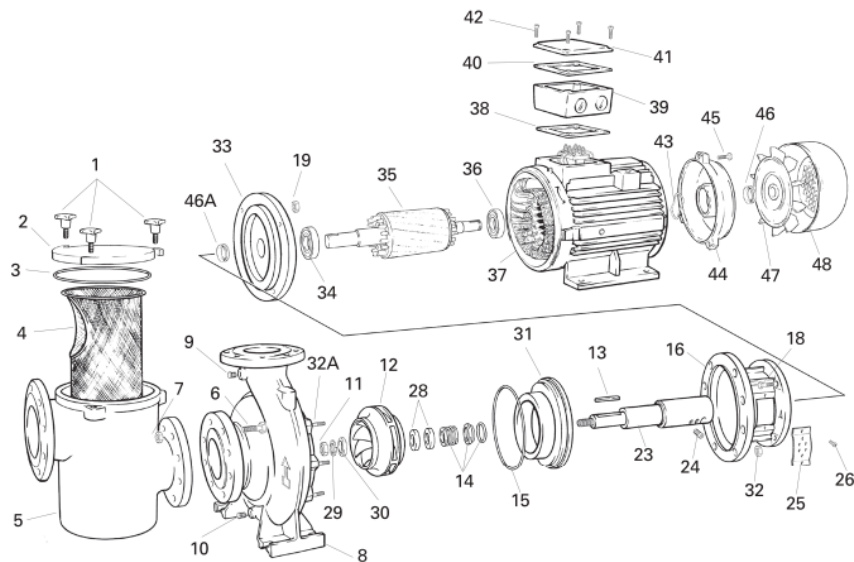

- 1 - POMO PREFILTRO
- 2 - TAPA REGISTRO PREFILTRO
- 3 - JUNTA TAPA REGISTRO
- 4 - CESTA PREFILTRO
- 5 - PREFILTRO
- 6 - TORNILLO PREFILTRO-CUERPO
- 7 - TUERCA PREFILTRO-CUERPO
- 8 - CUERPO BOMBA
- 9 - TORNILLO CEBADO
- 10 - TORNILLO VACIADO
- 11 - TUERCA TURBINA
- 12 - TURBINA
- 13 - CHAVETA
- 14 - CIERRE MECÁNICO
- 15 - JUNTA TORICA CUERPO BOMBA
- 16 - SOPORTE BOMBA MOTOR
- 18 - TORNILLO SOPORTE-MOTOR
- 19 - TUERCA TORNILLO SOPORTE-MOTOR
- 23 - EJE ACOPLAMIENTO
- 24 - TORNILLO SUJECCIÓN ACOPLAM
- 25 - TAPA ACOPLAMIENTO



- 26 - TORNILLO FIJACIÓN TAPA ACOPLAM
- 28 - SEPARADOR TURBINA
- 31 - BRIDA SOPORTE BOMBA
- 32A - PASADOR ROSCADO
- 32 - TUERCA PASADOR ROSCADO
- 33 - TAPA DELANTERA MOTOR
- 34 - RODAMIENTO DELANTERO
- 35 - EJE ROTOR
- 36 - RODAMIENTO TRASERO
- 37 - ESTATOR CON CARCASA
- 38 - JUNTA CAJA CONEXIONES
- 39 - CAJA CONEXIONES
- 40 - JUNTA TAPA CONEXIONES
- 41 - TAPA BORNES
- 42 - TORNILLO TAPA BORNES
- 43 - ARANDELA LASAJE
- 44 - TAPA TRASERA MOTOR
- 45 - TORNILLO TAPA TRASERA
- 46 - RETÉN TAPA TRASERA MOTOR
- 46A - RETÉN TAPA DELANTERA MOTOR
- 47 - VENTILADOR
- 48 - TAPA VENTILADOR

- 1 - PRE-FILTER HANDLE
- 2 - PRE-FILTER INSPECTION COVER
- 3 - INSPECTION COVER SEAL
- 4 - PRE-FILTER BASKET
- 5 - PRE-FILTER
- 6 - PRE-FILTER-BODY BOLT
- 7 - PRE-FILTER-BODY NUT
- 8 - PUMP BODY
- 9 - FILLING BOLT
- 10 - EMPTYING BOLT
- 11 - IMPELLER NUT
- 12 - IMPELLER
- 13 - PIN
- 14 - MECHANICAL SEAL
- 15 - PUMP BODY O-RING
- 16 - MOTOR PUMP SUPPORT
- 18 - MOTOR SUPPORT BOLT
- 19 - MOTOR SUPPORT NUT FOR BOLT
- 23 - COUPLING SHAFT
- 24 - COUPLING SUPPORT BOLT
- 25 - COUPLING COVER



- 1 - POIGNÉE PRÉFILTRE
- 2 - CAPOT CONTRÔLE PRÉFILTRE
- 3 - JOINT CAPOT CONTRÔLE
- 4 - BAC PRÉFILTRE
- 5 - PRÉFILTRE
- 6 - VIS PRÉFILTRE-CORPS
- 7 - ÉCROU PRÉFILTRE-CORPS
- 8 - CORPS POMPE
- 9 - VIS GRAISSÉE
- 10 - VIS À VIDE
- 11 - ÉCROU TURBINE
- 12 - TURBINE
- 13 - GOUPILLE
- 14 - FERMETURE MÉCANIQUE
- 15 - JOINT TORIQUE CORPS POMPE
- 16 - SUPPORT POMPE MOTEUR
- 18 - VIS SUPPORT-MOTEUR
- 19 - ÉCROU VIS SUPPORT-MOTEUR
- 23 - AXE COUPLE
- 24 - VIS FIXATION COUPLE
- 25 - CAPOT COUPLE

- 26 - VIS FIXATION CAPOT COUPLE
- 28 - SÉPARATEUR TURBINE
- 31 - BRIDE SUPPORT POMPE-MOTEUR
- 32A - GOUPILLE FILETÉE
- 32 - ÉCROU GOUPILLE FILETÉE
- 33 - CAPOT AVANT MOTEUR
- 34 - ROULEMENT AVANT
- 35 - AXE ROTOR
- 36 - ROULEMENT ARRIÈRE
- 37 - STATOR AVEC CARCASSE
- 38 - JOINT BOITE BORNES
- 39 - JOINT BOITE
- 40 - JOINT CAPOT CONNEXIONS
- 41 - CAPOT CONNEXIONS
- 42 - VIS CAPOT CONNEXIONS
- 43 - RONDELLE DE BUTÉE
- 44 - CAPOT ARRIÈRE MOTEUR
- 45 - VIS CAPOT ARRIÈRE
- 46 - BUTÉE CAPOT ARRIÈRE MOTEUR
- 46A - BUTÉE CAPOT AVANT MOTEUR
- 47 - VENTILATEUR
- 48 - CAPOT VENTILATEUR